

eFOLDi Powerchair

Model : HBLD3-D



USER MANUAL

eFOLDi[®] 



Contents

■ Terms, conditions and disclaimers	2
■ Welcome	4
■ Product overview	6
■ Components	7
■ Safety guidance	9
■ Unfolding instructions	12
■ Folding instructions	14
■ How to drive your eFOLDi	16
■ Battery info and charging	19
■ Checks and maintenance	22
■ Additional information	23
■ Frequently asked questions	26
■ Technical specifications	28

The terms 'us', 'we', 'our', 'SunTech UK' and SunTech UK Ltd' mean SunTech UK Limited, which is a UK registered company, limited by guarantee, registered with Companies House, number 06906908. The terms 'website' means the website found online at 'www.eFOLDi.co.uk' and/or 'www.eFOLDi.com'. The terms 'you', 'your', 'user' and 'rider', mean the person using the eFOLDi notwithstanding any person(s) handling the eFOLDi on behalf of the user, if different to the user, including general handling, maintenance, repairs and so on.

PURCHASER'S AGREEMENT

By accepting delivery of this eFOLDi, you undertake to not change, alter or modify this eFOLDi and/or any parts supplied with it or subsequently for it, and/or render inoperable or unsafe, any guards, shields or other safety features of this product; fail, refuse or neglect to install any retrofit kits from time to time, as may be provided by SunTech UK Ltd to enhance and/or preserve the safe use of this product. You also agree to accept and abide, by/with the terms and conditions contained herein and as may be revised from time to time and updated on our website, being immediately applicable. By using the eFOLDi and/or accessories and/or components supplied with or for the eFOLDi, the user acknowledges having read and understood the use(s) and limitations of the product(s) without exceptions. This shall not act as a waiver of any implied warranties, which customer retains, as provided by law.

Warranties will be void and SunTech UK Ltd will accept no responsibility whatsoever or howsoever, in instances of misuse and/or abuse of the products, in part or in full, by the user and/or any unauthorised persons, which may include (but not to be limited to); the user(s) failing to comply with all legal requirements and guidelines, wherever and/or however it is used or intended to be used, lack of or inappropriate maintenance, maintenance (apart from the routine maintenance as described in this manual by the user) by anyone not approved to do so, unapproved repairs, unauthorised disassembly of the vehicle and/or components including (but not limited to) battery pack(s) and controllers, unapproved modifications or alterations, failure to ensure correct folding and unfolding procedures are followed precisely and in full, damage or injury howsoever caused, failure to apply all reasonable and appropriate safety precautions at all times, improper use of the vehicle and/or parts and/or accessories, being used by more than one person at any times, use in any competitive sport, racing, stunts, jumping or other similar activity.

Our liability and the liability of our suppliers, to you or any third parties in any circumstances is limited to the user's cost of qualifying products purchased. Qualifying products as acceptable for the return, as outlined in the returned policy, as stated on the website online at: www.eFOLDi.co.uk and/or 'www.eFOLDi.com'.

Information in this user manual is subject to change without prior notice. For the latest updates and information, please go to our website online at: www.eFOLDi.co.uk and/or 'www.eFOLDi.com'.

Terms, conditions and disclaimers



THE eFOLDi POWERCHAIR SHOULD NOT BE USED BY

- **People with a mental impairment which requires ongoing supervision or assistance.**
- **People with slow reactions and who have difficulty in handling power mobility devices.**

CLASSIFICATION

According to the classification of medical devices, this electric wheelchair belongs to the ward nursing equipment and appliances (6856) management category for second class. Classified by operation mode: continuous operation.

According to the number of users: single use of equipment.

Classification by anti-electric shock: internal power supply.

Classification according to the degree of anti-electric shock: BF application part. Classification according to the degree of protection against liquid injection: IP3X.

According to the classification of electric wheelchairs: electric outdoor wheelchairs.

SHIPPING AND DELIVERY

Before using your eFOLDi , make sure your delivery is complete as some components may be individually packaged. If you do not receive a complete delivery, please contact us immediately. Where damage has occurred during transport, either to the packaging or the content, please contact the delivery company responsible.

Welcome



Thank you for choosing an eFOLDi Powerchair as your mobility solution.

I'm Sumi Wang, the founder of Suntech UK and co-inventor of the eFOLDi and would like to welcome you to the eFOLDi family of users.

Suntech UK manufactures a range of assistive technologies to help you get the most from life. Our mission is to give our customers freedom, friendship and fun with a range of easy to use, convenient and market leading mobility solutions.

Your eFOLDi has been manufactured to the highest standards and quality checked by our own pre-sales technicians before delivery to provide you with a product that will give many years of freedom and fun with reliable service.

Please take some time to read the user manual and the supplied documents before using your eFOLDi for the first time, this will help you understand the product and help you obtain maximum enjoyment and safety from your new eFOLDi Powerchair. You will quickly become familiar with the features of your eFOLDi with a little practice.

Suntech UK prides itself on its high-quality products and customer support so please remember to return the warranty form and retain all of the supplied documents in a safe place. These will help us to assist you in the event of any difficulties you may experience in the future.

I am sure you will find your eFOLDi Powerchair to be a reliable friend and companion and I thank you for your custom and your trust in our products.

Yours,

A handwritten signature in blue ink that reads 'Sumi Wang'.

Sumi Wang

Useful Information for you

Website address	www.efoldi.com
Email	services@efoldi.com
Facebook	www.facebook.com/efoldi.co.uk



Product overview

Thank you for purchasing our eFOLDi Powerchair. This ultra-light electric wheelchair has been carefully researched and developed to be light, energy efficient and easy to operate. Please read this manual carefully before use, so that you are familiar with all the various functions, and understand the required maintenance. This will ensure that the Powerchair remains in good condition and is safe to use.

Model: HBLD3-D



Components

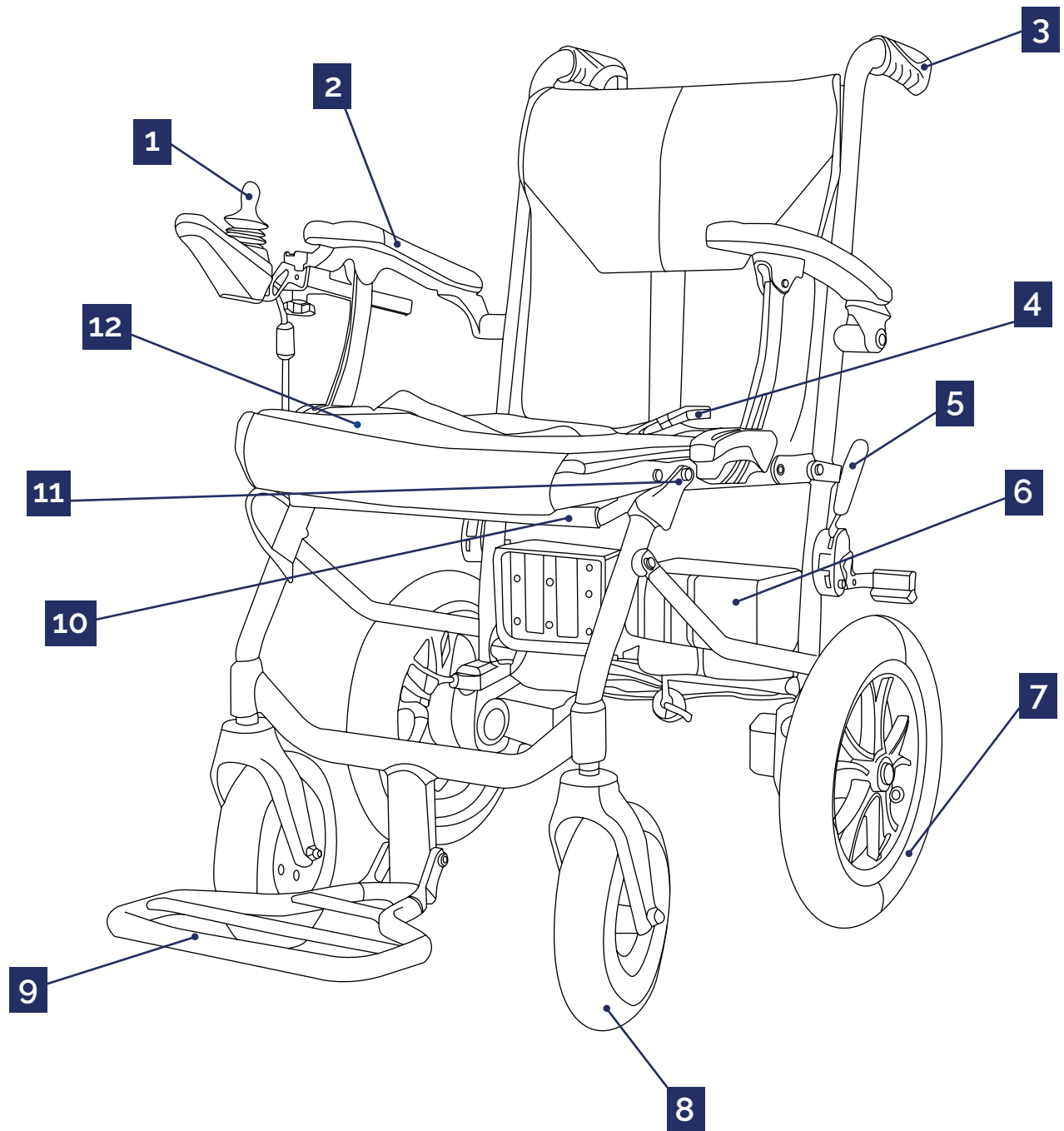

PARTS LIST

1	Joystick control
2	Armrest
3	Push handle
4	Seatbelt
5	Handbrake
6	Battery

7	Rear wheel
8	Front wheel
9	Footrest
10	Folding release bar
11	Folding Mechanism
12	Seat

Control bar components

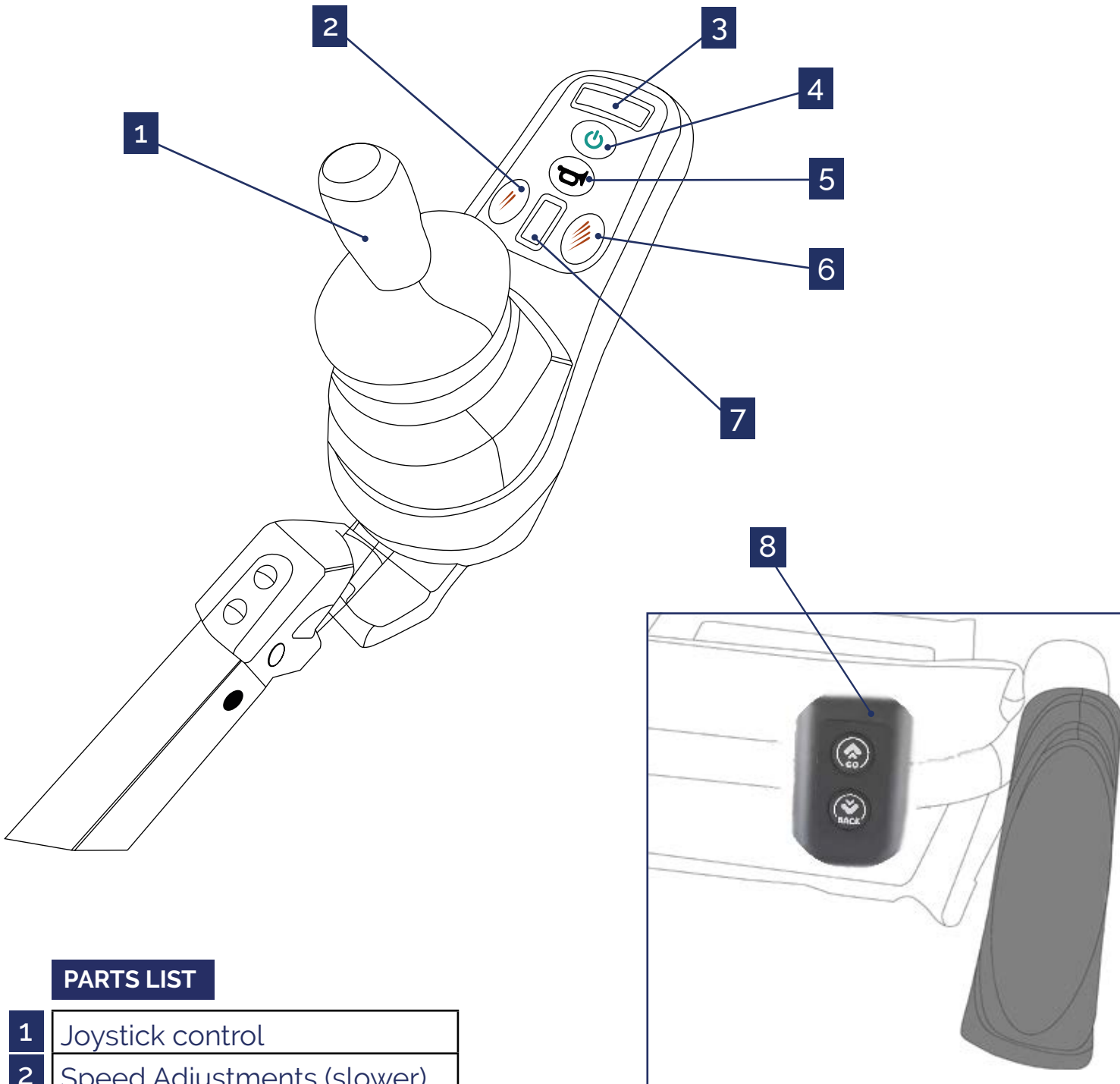

PARTS LIST

1	Joystick control
2	Speed Adjustments (slower)
3	Battery charge display
4	Power Button
5	Horn
6	Speed Adjustments (faster)
7	Speed Display
8	Assistant control

Safety guidance

THIS PRODUCT IS SUITABLE FOR

Persons with mobility difficulties, but with complete behavioural ability, or with access to care and assistance.

Weight limit of 135kg (/297lbs).

- It is the users responsibility to read the manual and supplied documents before using the eFOLDi Powerchair and to follow all of the recommendations contained within, to fully comply with all local laws of their countries and localities and to use the eFOLDi Powerchair with due diligence and regard to other pedestrians.
- The eFOLDi Powerchair is simple to use, but its folding mechanism can cause injury if used inappropriately and handled without due care and diligence. To avoid any risk of injury ensure hands, fingers, jewellery, clothing and other objects are not allowed to interfere with the folding mechanism or moving parts of the eFOLDi Powerchair. Study the manual carefully before you start operating your eFOLDi.
- It is advised that the user familiarise themselves with the folding and unfolding procedure before venturing outside. The user should also ensure that they familiarise themselves with the controls and handling of the Powerchair in a safe area away from obstacles and other pedestrians or road users.
- Fully charge the battery(ies) before first use and follow the guidelines in this manual for prolonging the life of your battery.

EMC WARNING STATEMENT

This Powerchair meets the requirements of electromagnetic compatibility of YY0505 and GB/T 18029.21 standards. This is a Class A product. In a domestic environment, this product might cause radio interference in which case the user might be required to take adequate measures.

Safety guidance

CAUTION



- Cannot be driven on the road.
- Be sure to slow down before turning.
- Do not ride over rough, cobbled, muddy or loose gravel surfaces. Your eFOLDi Powerchair is designed for smooth and firm footpaths and pedestrian areas only.
- Any vehicle can be dangerous to its rider/driver and other road users and pedestrians. Always ride/drive responsibly, respectfully and with due care to others.
- Your eFOLDi Powerchair is NOT a toy and is not recommended for people under the age of 14. Do not allow children to play with or on the Powerchair. The folding mechanism can cause injury to small hands.
- Do not operate your eFOLDi Powerchair until you have read and fully understood this manual.
- Do not operate your eFOLDi Powerchair until assembly and inspection is complete. It is suggested that people with mental abnormality, slow reactions and difficulty in handling powered devices should not use the eFOLDi Powerchair on their own.
- Do not get on or off the eFOLDi Powerchair when the power is on, or when the Powerchair is in free wheel mode or there is no carer to provide assistance.
- Do not drive your eFOLDi Powerchair in violation of national and local traffic regulations.
- Do not make sharp turns at high speed. Do not park the eFOLDi Powerchair on a ramp. Never make turns on a slope.
- Do not use the eFOLDi Powerchair on sandy or soft ground.
- Avoid driving on slopes greater than 6 degrees or over obstacles greater than 4 cm in height.
- Do not disassemble or change parts of the eFOLDi Powerchair or replace parts not manufactured by the manufacturer without the manufacturer's permission.

Safety guidance

When unfolding/folding your eFOLDi Powerchair ensure

- The eFOLDi is positioned on a level floor or ground.
- Main switch is switched off.
- All latch pins are properly secured in place, as stated on the instructions.
- Handbrake is disengaged.

Safety check before use

It is highly recommended that you perform a safety check before each use to make sure your eFOLDi operates smoothly and safely.

Check for correct tyre inflation. Maintain but do not exceed the PSI/BAR/kPa air pressure rating indicated on the pneumatic rear tyres and be sure to use the correct pressure scale and according number on your inflator/taster. ✓

Check all electrical connections. Make sure they are secure and not corroded. ✓

Check and test the brake system. ✓

Check frequently for any loose fasteners, fixings and other components. ✓



WARNING

Except for approved items sold by the manufacturer, do not use accessories or charging leads from 3rd party suppliers. This could result in damage and will void the warranty of the Powerchair.



Warning. Should not be opened by non-professionals



High voltage



Type BF



Environmental protection

IPX3 Level of water resistance

Unfolding instructions

STEP 1:

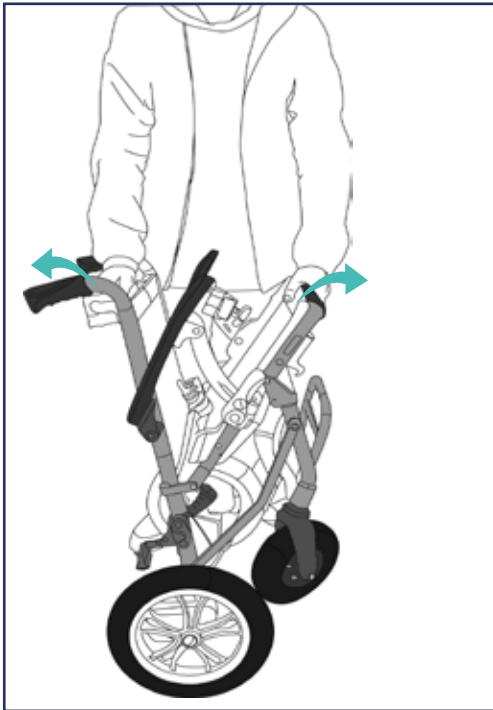

1. Once removed from the packaging place the wheelchair on a stable surface. Place one hand on the top of the backrest and the other hand on the latch bar underneath the seat, in the front part of the folded Powerchair. Finally push your two hands apart until the seat is open at 90° degrees and you hear a distinct “click” sound.

STEP 2:

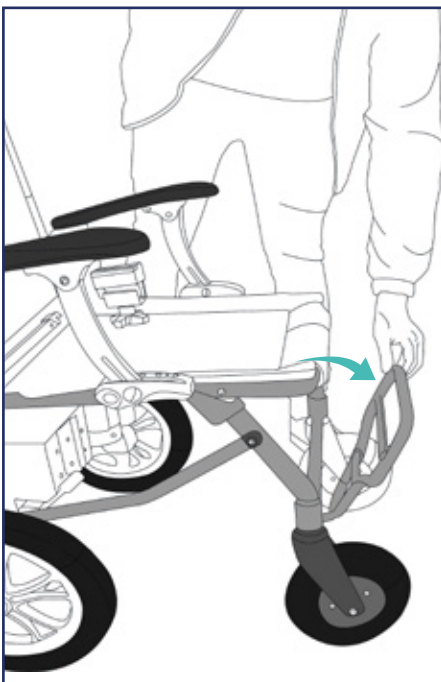

2. Unfold the footrest, from a vertical position to a 90° degrees horizontal position.

Unfolding instructions

STEP 3:

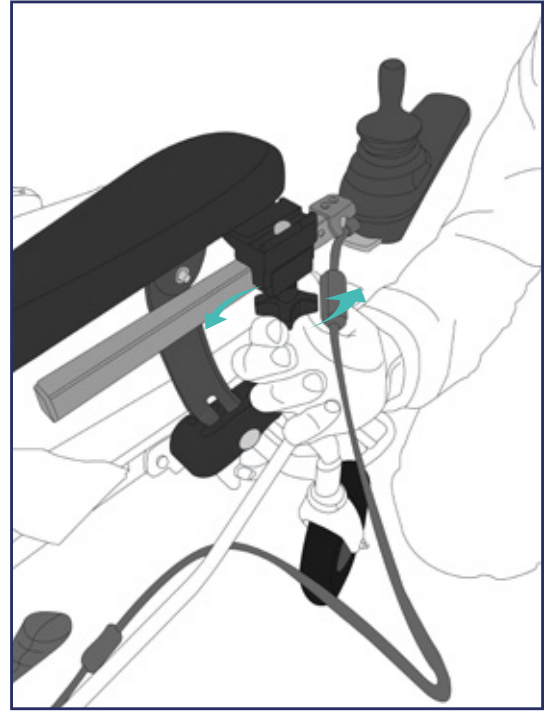
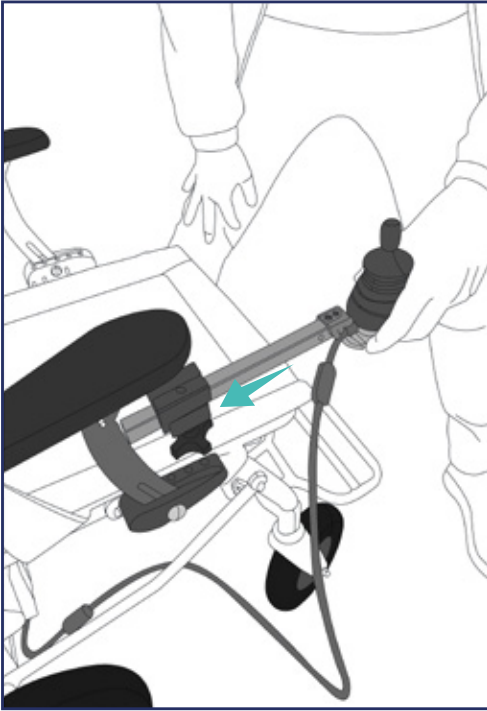

3. Finally slot the joystick arm inside the frame and push it, into a comfortable horizontal position, where it is easy for your hand to reach the joystick. Once you are happy with the horizontal position of the joystick arm, lock it by tightening the clamp.



Your eFOLDi Powerchair is ready to be used!

Folding instructions

STEP 1:

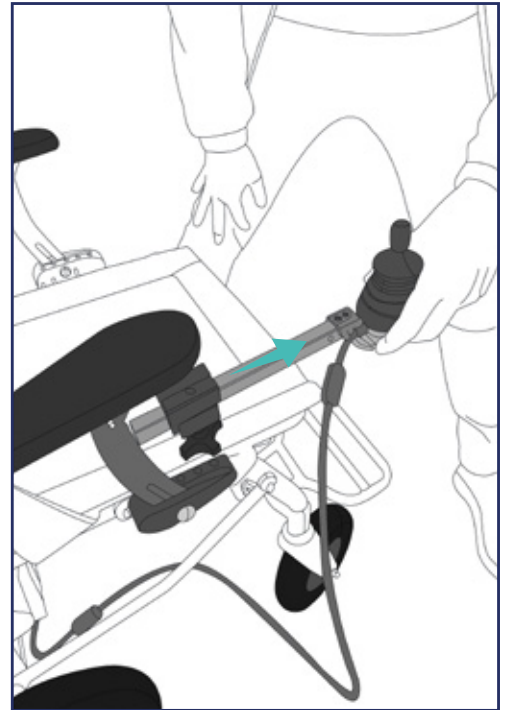
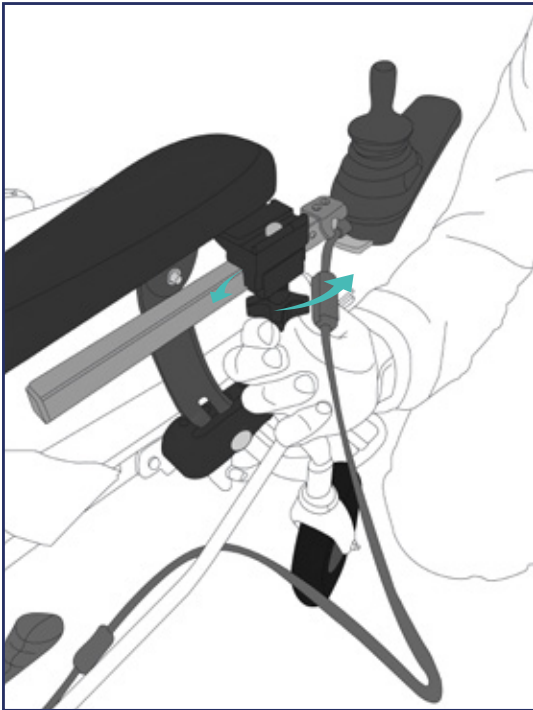

1. Loosen the tightening clamp, to release the joystick arm. Take out the joystick arm and place it on the Powerchair seat.

STEP 2:

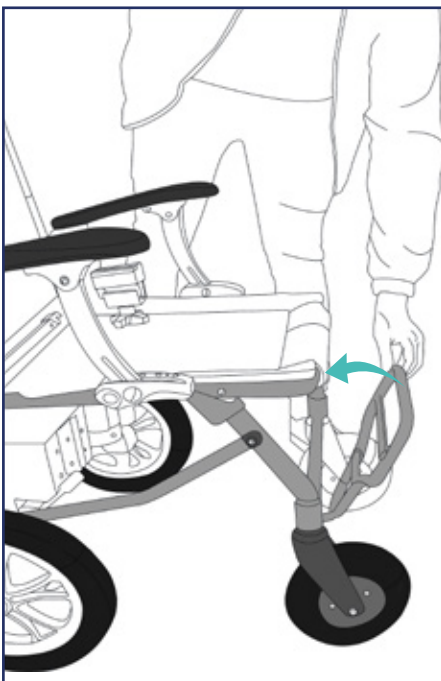

2. Fold the footrest, at 90° degrees position vertically.

Folding instructions

STEP 3:

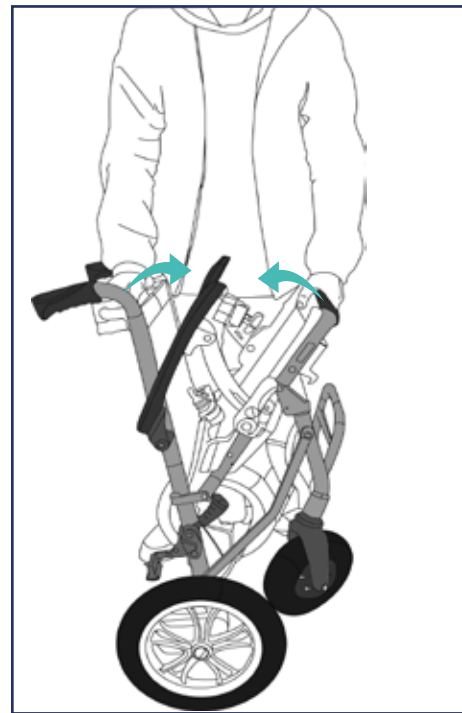

3. Place one hand at the top on the backrest bar and the other on the folding lever underneath the seat and by pressing it and bringing your hand together, close and fold the eFOLDi Powerchair.

To make this last step more efficient, make sure you do this on a stable ground surface and that the front wheels don't get in the way during this process, as they may get stuck by being jammed with the back wheels.



Your eFOLDi Powerchair is ready to be stored, or transported.

How to drive your eFOLDi

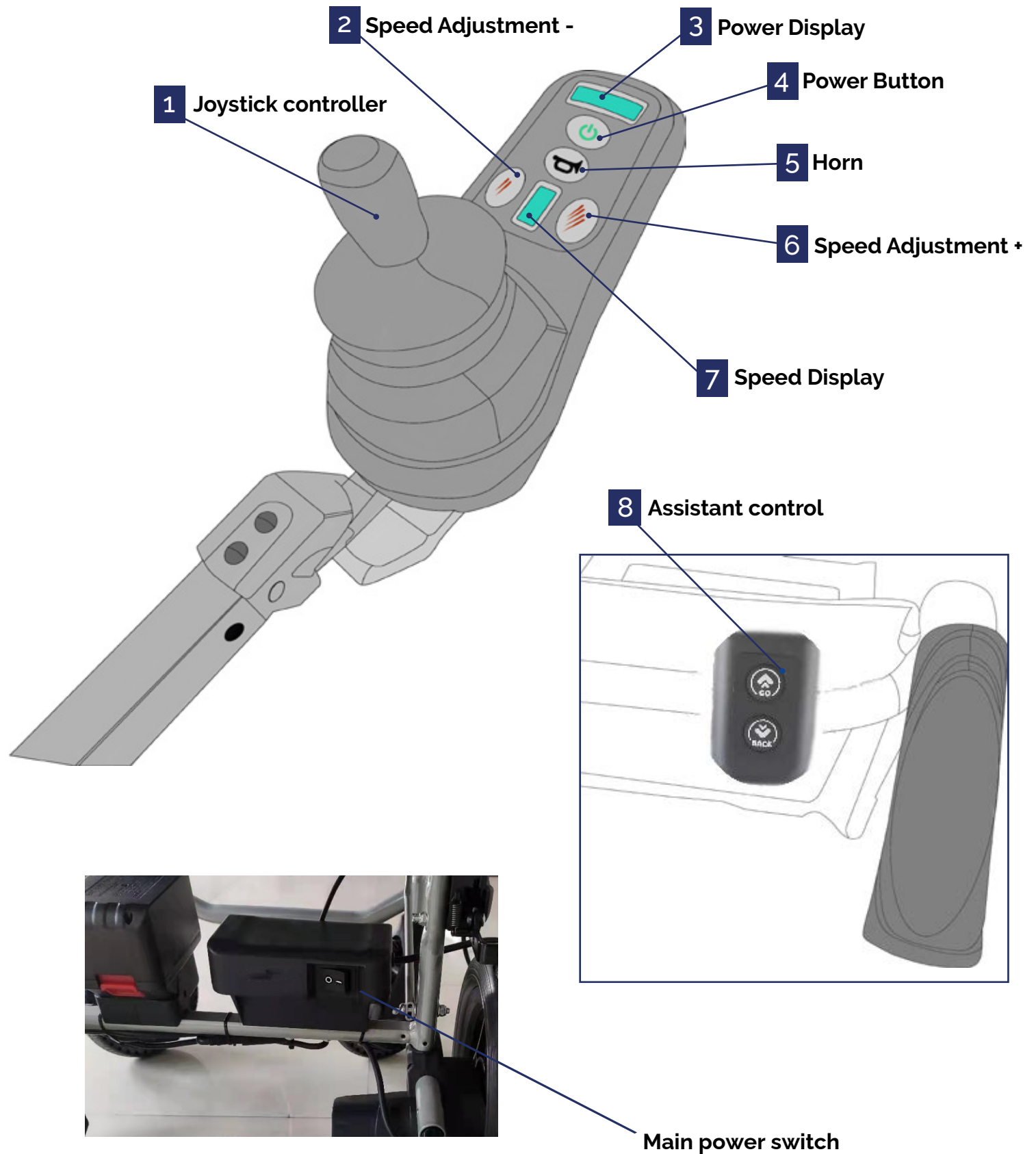

How to drive your eFOLDi

- 1 Joystick controller:** controls the direction and speed at the same time, slowly push the joystick towards the driving direction, then the eFOLDi Powerchair will start to move, push the joystick further and you will notice greater acceleration.
- 2 Speed adjustment - :** It is positioned just above the control handle on the left hand side, and it decreases the speed to make the eFOLDi Powerchair easier to control.
- 3 Power Display:** Shows the battery charge remaining.
- 4 Power Button:** Switches the power on and off by pressing the button (Make sure the main power switch is on).
- 5 Horn:** Positioned right in the middle of the control panel, use this to warn other pedestrians, of your presence.
- 6 Speed adjustment + :** It is positioned just above the control handle on the right hand side, and by pressing the button it increases the speed level of the powerchair to go faster. Always be aware of your speed.
- 7 Speed Display:** Indicates what speed is currently selected.
- 8 Assistant control:** Allows an assistant to power the chair for easy handling.

Any deviation from level/horizontal surfaces should not exceed a gradient of 1:10 (6 degrees). For any climbing there are many factors to be considered these are: the tyre pressure and condition, the surface condition (if wet, icy or slippery, and this includes leaf cover and/or other debris, we advise against driving the slope)

How to drive your eFOLDi

CAUTION



When parking on a ramp, the electromagnetic brake may not always be strong enough. Always use the manual brake in conjunction with the electromagnetic brake.

Free wheel mode



Switch off the main power supply from the control box at the back of the power chair.

This electric wheelchair is suitable for driving on flat road, driving on muddy, potholed and uneven road could cause damage to the transmission mechanism and control system of electric wheelchair. Before getting off, first turn off the power on the controller, press down the manual brake, return the footplate to it's upright position, and then get off.

Battery info and charging



The eFOLDi Powerchair battery has been designed and built specifically for the eFOLDi Powerchair. This battery must not be used for any purpose other than as stated in this manual. Any misuse or dismantling of this battery may damage it physically and/or electrically, internally and/or externally will not be covered by the warranty.

The battery contains no user serviceable or replaceable components.

The eFOLDi Powerchair battery is actually a battery pack, comprising a number of lithium/ion cells, but merely termed 'battery' for ease throughout this manual. This battery is different in characteristics and charging requirements to the old and still quite common lead/acid or lead/gel type. Never use a lead type charger to charge it.

To ensure best long-term use of the battery, please observe the following safety rules at all times

- Connection dock must be handled with care to avoid damage.
- Charge the battery only with the approved charger.
- Never use a charger for lead type batteries on the eFOLDi battery.
- Never place the battery near, on or against any heat source.
- Ensure no metal parts can touch (or 'short') battery or charger terminals, connectors, pins or any other electrical conductor(s) or conducting parts.
- Avoid excessive physical impact and vibration of the battery.
- Do not attempt to dismantle, dissect or deform the battery(ies) or case(s).
- Do not immerse the battery in any liquid (including water).
- Do not mix different types of batteries.
- Keep the battery out of reach of children.
- Do not use modified or damaged chargers.
- Do not leave the battery on charge for more than 24 hours.
- Store the battery in a cool, dry, well ventilated area
- Dispose of the battery only in accordance with local laws and regulations.
- Batteries should not be stored for long periods without charging. It is recommended the battery to be charged monthly to prolong its life.



Battery info and charging



Switch on the power, the power indicator light in the front row will be on, full power will show 5 lights (2 red, 1 yellow, 2 green). When the two red lights are flashing, this indicates that the battery requires charging.

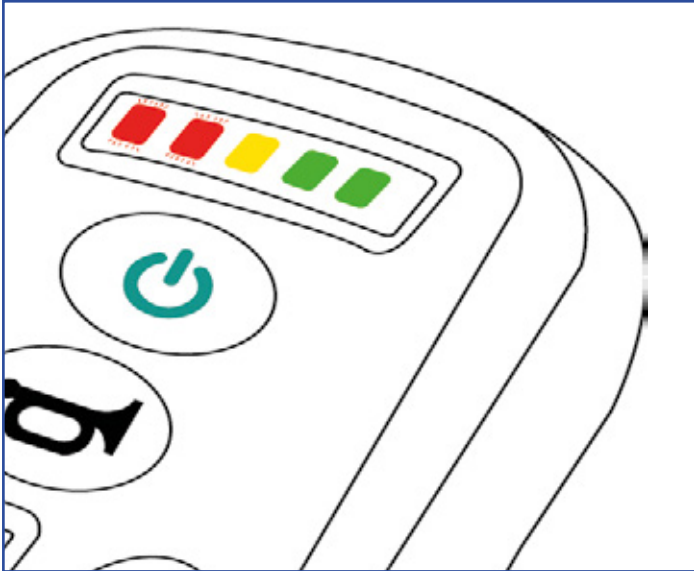

Fitting the battery into the eFOLDi

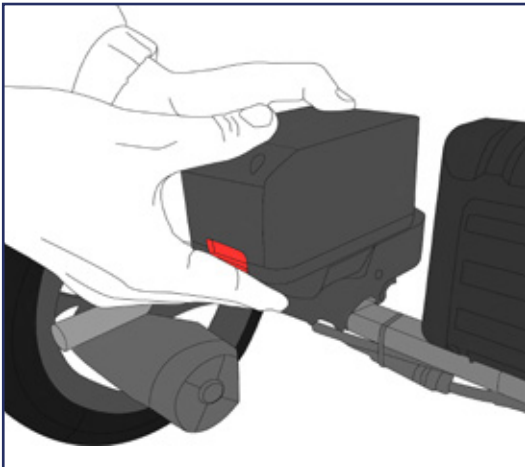

To remove the battery for charging, push the red button down, hold the battery on the outside, and release from the Powerchair. To put it back, slide the battery into the battery guide slot, push it until you hear a click, then the battery is inserted securely.

CAUTION

Please remove the battery and charge it once a month if not in use (Powerchair batteries ideally should not be stored in the Powerchair).

Battery info and charging



Charger and charging

Precaution for use and handling of the charger

Use only the charger originally supplied with your new eFOLDi Powerchair or replacement charger supplied by SunTech UK Ltd for the use with your product. The use of a non-approved charger will invalidate any warranty and may cause serious damage to the battery and/or your eFOLDi product. The charger should not be used with or for other devices as damage caused to the charger and/or any other device by doing so will not be covered by our warranty.

It is highly recommended to ensure the charger is placed only on heat resistant surfaces and nothing which could contribute to a fire (e.g. carpet, floorboards, wood, laminate or plastic worktops etc)- the charger will heat up during a normal charging cycle, as will the battery.

Do not leave the battery on charge for more than 24 hours, as this will reduce the life and performance of the battery.

Charging notes for international travellers.

For the benefit of international travellers, your approved eFOLDi charger can be used with any mains voltage supply from 100 to 240 Volts, with a suitable travel adaptor.

Using the charger

*Before obtaining an alternative cable, it is recommended you examine your eFOLDi charger to determine which type of plug it requires - it will be either a two -pin 'figure of 8' (IEC60320-1 C7), or a three-pin similar to a kettle (IEC60320-1 C13).

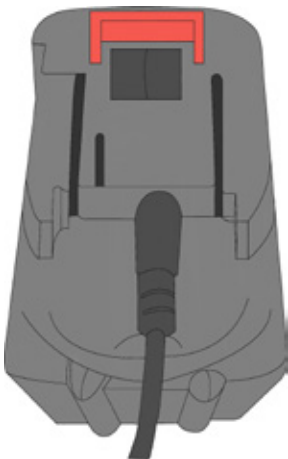



Perform the following inspections prior to using your eFOLDi daily

- Make sure you check the correct tyre inflation and maintain without exceeding the P.S.I./BAR/kPa air pressure rating indicated on each pneumatic tyre (note; the front and rear tyres are different pressures). Also be sure to use the correct pressure scale and according number on your inflater/pressure tester.

Perform the following inspections weekly

- Check the fastening condition of each nuts, bolts and screws to make sure all the parts are properly secured and are not missing or loose
- Check all electrical connections. Make sure they are tight and not corroded.
- Electromagnetic brake: It is used as a driving brake. The braking distance should be more than 1.5 metres after you release the joystick to stop.
- Tyre pressure: front tyres 8x2 inch 250kpa (36psi), solid rear tyres.
- **Have your eFOLDi regularly serviced each year.**

Cleaning and maintenance

- Regular cleaning and maintenance of the vehicle helps to maintain a beautiful appearance and extend the life of the product. Metal and plastic parts can be wiped with a soft cloth, which has been washed and wrung. Soft cloth can be dipped in a mild detergent.

CAUTION

**Oil and other lubricants must not be used on the following parts:
Brake pads, brake cable, tyres.**

Additional information

Troubleshooting

Most of the failures of the electric wheelchairs are related to the battery. Check the battery condition before changing parts.

Malfunction:

Possible cause:

Solution:

Battery fails to charge

- Abnormal AC power supply
- Charger failure
- Battery failure

- Check the power supply
- Contact eFOLDi support
- Change the battery

No power after the power button is pushed

- Battery not in the battery bay
- Battery not inserted properly
- Loose power cable
- Battery failure
- Low battery

- Install the battery
- Insert correctly
- Check the power cable
- Change the battery
- Charge the battery

Unable to move or move irregularly

- Controller or motor failure
- Handbrake(s) engaged

- Contact eFOLDi support
- Release handbrake(s)

Electromagnetic interference

The electromagnetic wave emitted by this product may interfere with certain other medical equipment. Please be sure to comply with the regulations of the building when using in premises where this may occur. Radio waves (radio, television, amateur radio transmitters, walkie-talkies, fixed telephones) affect electric wheelchairs. Following these warnings will reduce the risk of loss of control or brake failure, which can lead to serious injury or equipment damage.

- 1** Do not turn on hand held communication devices, such as medium and short- wave radios and mobile phones, while the electric wheelchair is in use;
- 2** Notice nearby transmitters, such as radio or television stations, and try to avoid them;
- 3** In the case of the wheelchairs losing control or suffering brake failure, shut down the power as soon as possible;
- 4** Be aware of additions or modifications to attachments that may increase sensitivity to radio waves (note: it is not easy to assess their effects in electric wheelchairs);
- 5** Contact eFOLDi support if the Powerchair appears to be out of control and note if there is a radio source nearby.

Additional information

Precautions

First of all, thank you for purchasing our eFOLDi Power Chair. Second, please pay attention to the following matters in daily use: Do not disassemble the battery. In case of serious battery impact, please contact eFOLDi support immediately. Should the battery become soaked in water during use or storage, it must no longer be used and sent back to eFOLDi for testing

Precautions for battery use:

- A** Please charge the battery in a normal indoor environment.
- B** Please charge the battery with the manufacturer supplied charger only.
- C** Do not charge the battery for more than 8 hours
- D** Be sure to keep away from flammable and explosive materials during charging and storage.

Waste disposal

If the battery needs to be recycled or discarded, be sure to use tape to insulate part of the electrode. Contact with other metals will lead to battery overheating, rupture or fire. Send the used batteries to an approved recycle centre only.

Frequently asked questions



■ How much does my eFOLDi Powerchair weigh?

Your eFOLDi Powerchair weighs 14 Kg/ 31lbs

■ How much weight can my Powerchair carry?

Your powerchair can carry up to 135kg/ 297lbs

■ How fast does my eFOLDi Powerchair travel? Up to 6kmh/ 4mph

■ What tyre pressure should I pump my tyres up to?

Not required as both tyres are solid.

■ What size inner tubes will I need if I did get a puncture?

Both the front and the rear tyres are solid.

■ How do I change the front tyre/inner tube?

Unbolt the wheel nut and remove the wheel. When done simply reinstall the wheel and its wheel nut.

■ What sort of braking system does my eFOLDi Powerchair have?

The eFOLDi Powerchair has an electromagnetic brake, when you release the joystick the chair will come to a halt. In addition there is a manual brake which can be applied for when you are stopped on a slope or when you wish to be sure of staying stationary for instance while on a bus, boat or other vehicle.

■ How long does the battery take to charge?

Up to 5 hours.

■ Are there keys?

There are no keys.

■ Can I charge my eFOLDi Powerchair with the battery left in?

No - the battery must be removed to allow charging to take place.

■ The battery seems very small how far will my Power Chair go on a charge?

The range of any electric vehicle is limited by a great number of factors but typically your eFOLDi Power Chair will travel up to 6miles on a single charge per battery – up to 12 miles using both batteries, if on even dry conditions.

Frequently asked questions



The eFOLDi Powerchair comes with two batteries as standard. A main battery and a reserve. The reserve battery plugs into a cradle underneath the powerchair alongside the main battery. When the main battery is exhausted simply switch the batteries over.

■ **Can I take my eFOLDi Powerchair on an aeroplane?**

Yes. You can drive your eFOLDi Powerchair up to the cabin doors, where you will be asked to take out the battery and keep it with you for the duration of the flight. The powerchair will be taken to a secure part of the hold by the cabin crew and returned to you when you land.

■ **Do I need to register my Powerchair with the DVLA? (UK only)**

Your eFOLDi Powerchair does not require registration with DVLA.

■ **Can I change the control stick from the left to the right side of the chair?**

Absolutely - the control pad can be simply unlocked and moved to whichever side of the chair is most comfortable for you.

■ **Can I have someone just push the powerchair for me?**

Yes - the eFOLDi Powerchair has an attendant control so an attendant can either push you using power or they can disengage the motor and push the chair as a conventional unpowered chair.

Technical specifications

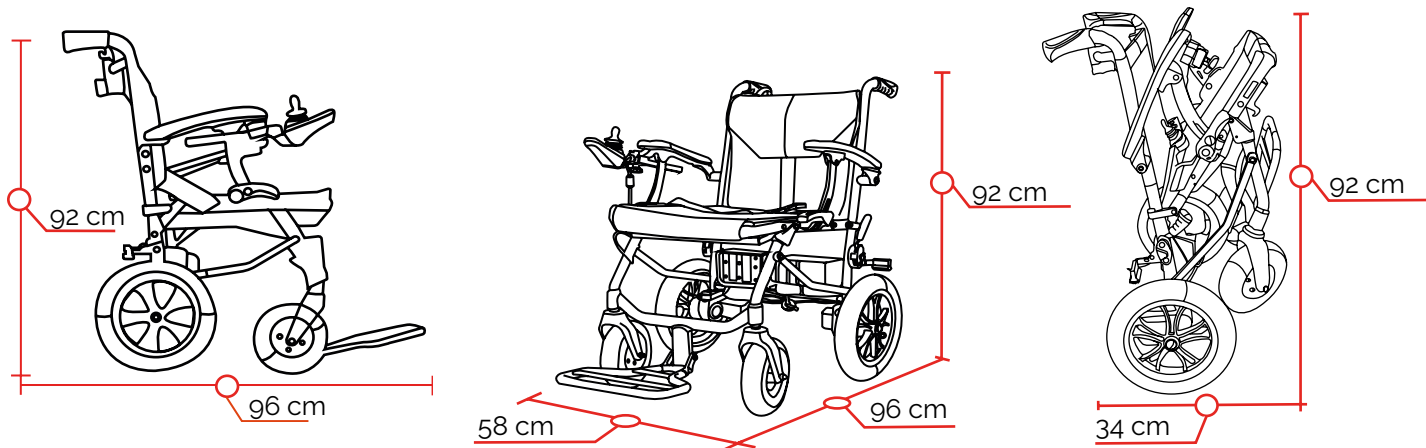

DIMENSIONS

Folded dimensions (L/W/H): 58x34x92cm (22x13x36")

Unfolded dimensions (L/W/H): 58x96x92 (22x38x36")

Packaging dimensions (L/W/H): 58x34x92cm (22x13x36")

Seat height: 48cm (19")

Footrest height: 3.5cm (1.5")

Front wheel size/pressure: 20cm(8")/36 psi

Rear wheel size: 30cm (12")

WEIGHT

Weight with battery: 15kg (32lbs)

Weight without battery: 14kg (31lbs)

PERFORMANCE

Speed: 6kmh / 4mph

Maximum range capacity: 12miles/20km

Maximum carry capacity: 135kg/297lbs

Maximum gradient percentage: 1:10 (6 degrees)

COMPONENTS CAPABILITY

Motor: 200W X2 24V Hub Motor

Battery standard: 5.2Ah Li-Ion

Brake: Electric Magnet

Main power supply: On the back of control box

Power switch: Power button on joystick

Number of wheels: 4

Tyre type: Front Solid / Rear Solid

ENVIRONMENT

Place to use: Pavement and indoor

Appendix



SunTech UK Ltd

25 Ormside Way, Holmethorpe Industrial Estate, Redhill, Surrey, RH1 2LW











TEL: +44 (0) 2031435168



MedPath GmbH

Mies-van-der-Rohe-Strasse 8, 80807 Munich, Germany

Symbol used on the Label

	Conformite Europeenne		Manufacturer
	Authorized representative in the European Community		Medical device
	Serial number		UDI
	Used by		Refer to instructions manual
	Avoid sunlight		Keep dry



eFOLDi®



SunTech UK Ltd
25 Ormside Way, Redhill
Surrey, RH1 2LW, UK



MedPath GmbH
Mies-van-der-Rohe-Strasse 8
80807 Munich, Germany

www.efoldi.com

Services@efoldi.com