

LEHNER LIFTTECHNIK

User Manual



≡ *Stairmax* ≡
*Mobile
stairlift*

A – 4724 Neukirchen/W, Salling 8
Email: sales@lehnerliffttechnik.at
0043/7278/3514
Webpage : www.lehner-liffttechnik.at

Tel: 0043/7278/3514-15,
Fax:

Mobile: 0043/664/3526190

Table of contents:

1. Introduction	2
2. Preconditions for the safe use of Stairmax	3
3. Restrictions for the use of the Stairmax	3
4. Adaptation of the wheelchair for the Stairmax	3
5. Operation	4
Main control functions	5
Checking of stair slope	6
Connecting the wheelchair to the Stairmax	6
Position 1: Horizontal driving	9
Position 2: Driving on Stairs	10
6. Width of landings	13
7. Maintenance	14
Batteries	14
Use of the charger	14
Prolonging the battery life-time	14
Storage of batteries	15
Rubber crawler	15
Parking and transporting the Stairmax	16
8. Technical details	17
9. Error-check table	18
10. Warranty	18

1. Introduction

Congratulations to your acquisition of the **Stairmax** mobile stair lift. The **Stairmax** is a further development of the well proven Stair-Aid to an innovating “do-it-yourself” stairclimber. In many cases, the **Stairmax** can act as a satisfactory alternative to an expensive platform stairlift.

This mobile stairlift is a cost-saving and unique stair aid, which enables active wheelchair drivers to drive up and down straight stairs with landings in their own wheelchair.

For every active wheelchair user, the **Stairmax** will represent a helpful and reliable partner for the future, provided a proper adapted wheelchair and the compliance with the subsequent instructions is given.

Mobility, independence, simple handling and robustness are the key features of the **Stairmax**. The technical assembly of the lift is simple and safety concerns were given highest regard in the development.

To guarantee your satisfaction with the **Stairmax** for a long time period please read this user manual carefully. Apart from use instructions you will find important security advices.

Please keep this manual for future use.

For accidents, that result as a consequence of the disregard of this manual *Lehner Lifstechnik GmbH* disclaims any liability.

We wish you great pleasure with your *Stairmax*!

2. Preconditions for the safe use of *Stairmax*

- Good arm and finger functionality of the user
- Mental capability, e.g. : such as is necessary to obtain a car drivers licence
- A thorough training of the wheelchair driver which should be done by the delivery company or the rehabilitation centre
- Only stable wheelchairs (active-wheelchairs) are to be used. The adaptation has to comply with the adaptation instructions as shown in this manual.
- Stairs where the ***Stairmax*** is used need to have at least one stable handrail

3. Restrictions for the use of the *Stairmax*

- The maximal loading capacity is 130 kg (wheelchair driver plus wheelchair) and must not be exceeded
- It is not allowed to drive on:
 - Spiral Staircases
 - Stairs with gradients greater than 35 °
 - Landings that are less than 1100 mm wide
 - Stairs that are not non-slip (e.g. wet or icy stairs)

4. Adaptation of the wheelchair for the *Stairmax*

The adaptation of the wheelchair has to be done by a competent person. The installation of the 2 adaptation pipes delivered together with the ***Stairmax***, which are to be mounted on the wheelchair is the most important aspect of the adaptation work. Depending on the constructive characteristics of the wheelchair the adaptation has to fulfil the safety and technical standards. The stability of the wheelchair may not be impaired.

5. Operation

The subsequent instructions, together with the photos and illustrations, should help to explain the important aspects of the **Stairmax** operation. Below the diagram gives an overview of the main **Stairmax** functions.

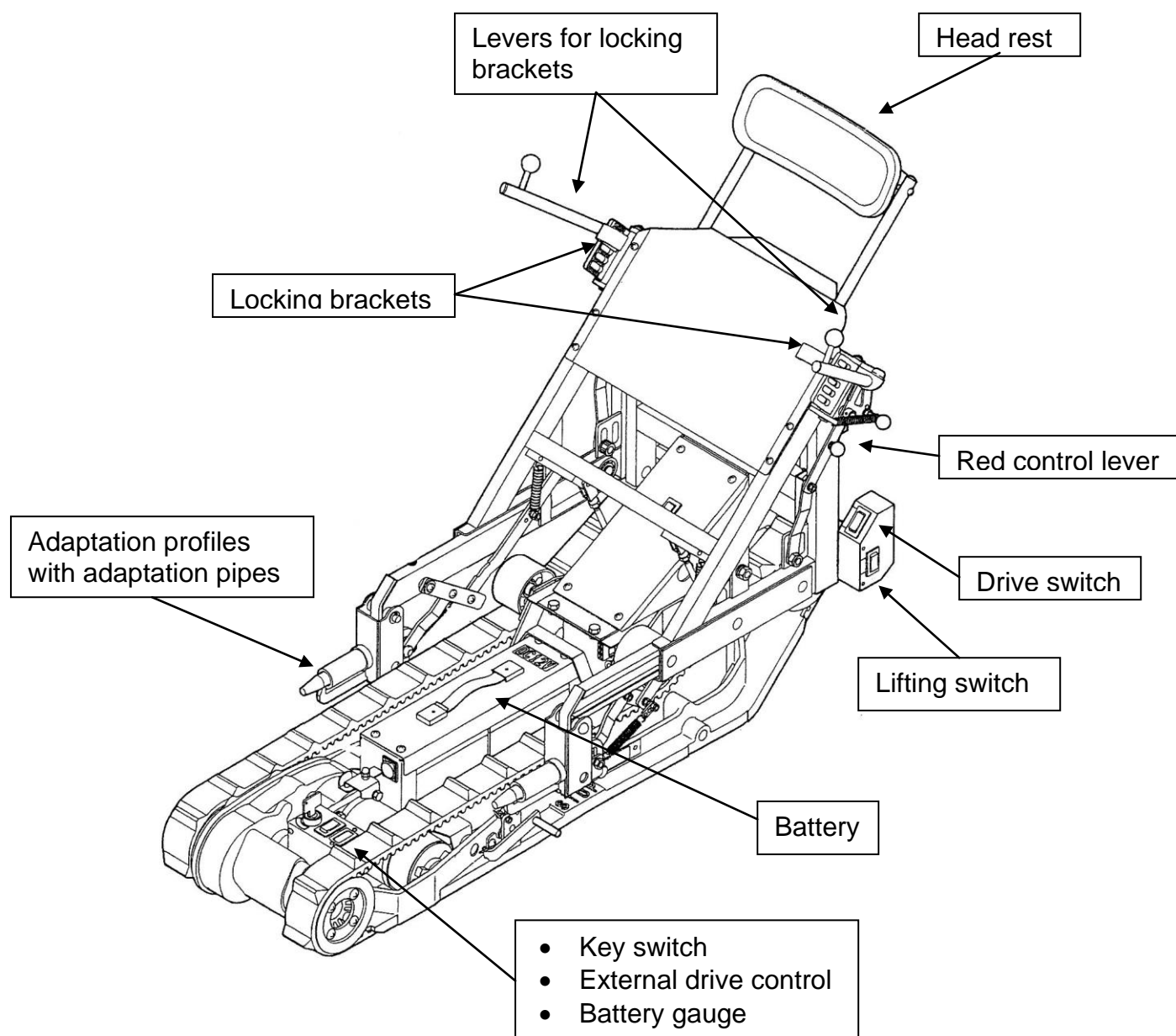

Main control functions

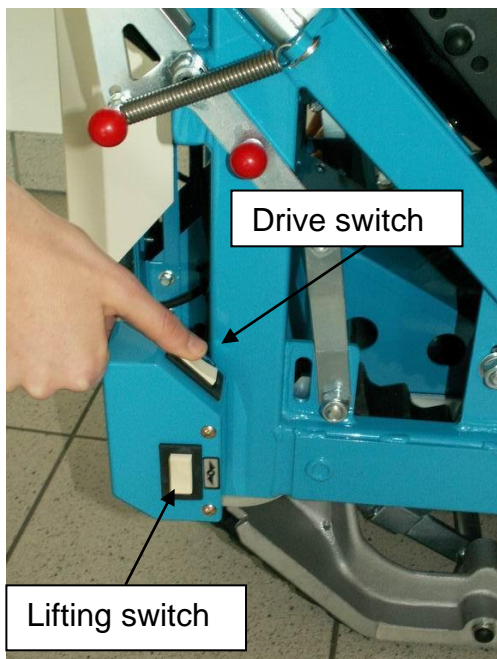

The lifting and drive rocker switches can be operated on both sides of the vehicle.



Emergency Stop buttons are also located on both sides behind the rocker switches. When pushed, they disconnect the electricity supply to the motor.

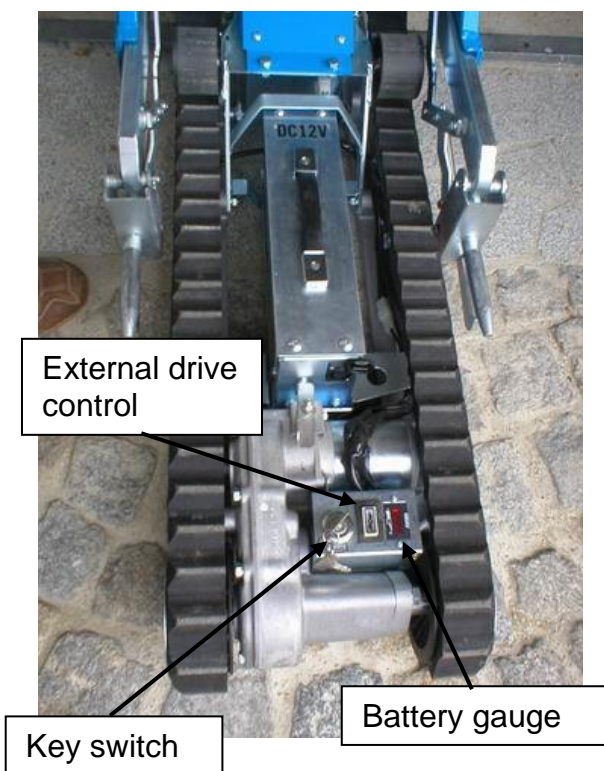

Key switch for ON/OFF and external drive control allow external operation

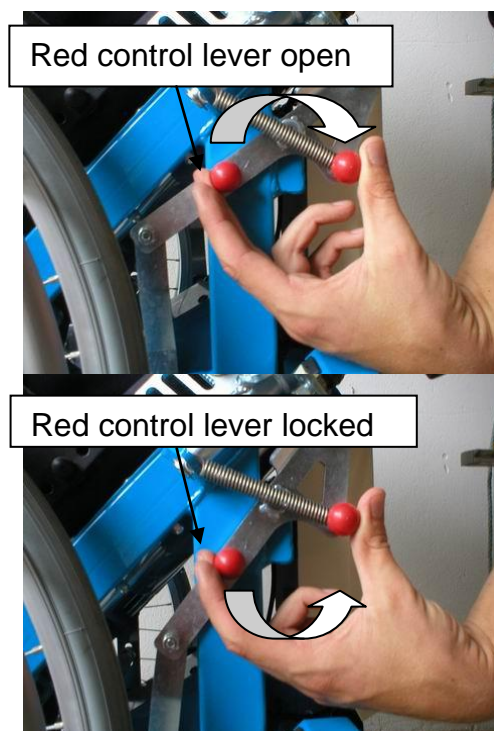

The red control lever has to be in closed position to lock the locking brackets and activate the drive switch

Checking of stair slope

Before a stair is driven upon, the respective gradient has to be checked and may not exceed 35°. When measuring the gradient with the special measuring tool delivered along with the **Stairmax**, the indicator has to remain within the green coloured area of the display. Steeper stairs (indicator is in yellow or red area) are not safe to be driven upon and the **Stairmax** may not be used in these cases.

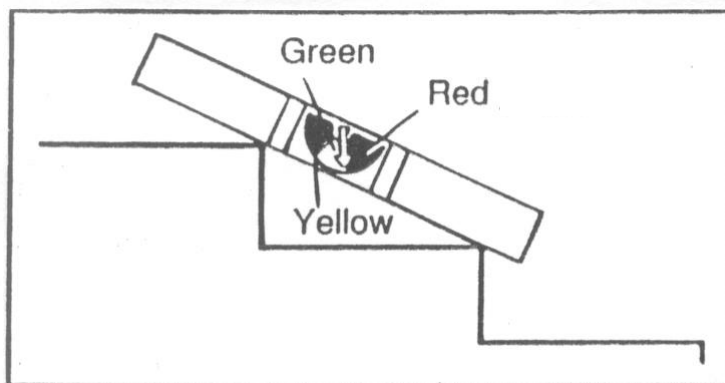

Connecting the wheelchair to the **Stairmax**

In order to be able to connect the wheelchair to the **Stairmax** the adapter must be in the upper position and the red control lever must not be in closed position. This unlocks the locking brackets for the wheelchair backrest and the adapter holder profiles are in the right position to connect to the adaptation pipes of the wheelchair. Only in this position it is possible to attach the wheelchair.

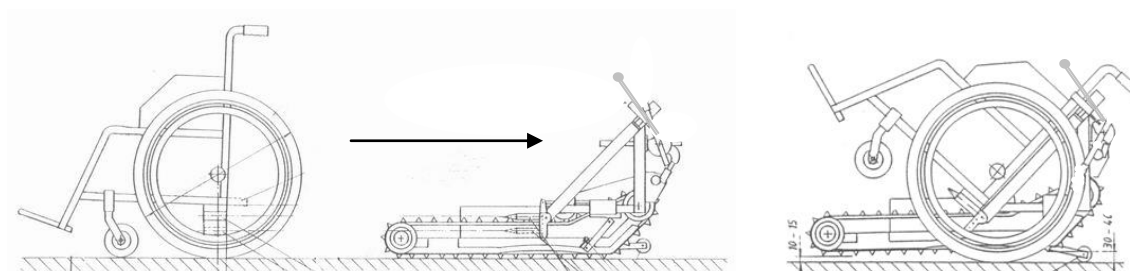

The wheelchair driver has to drive backwards over the **Stairmax** so that the adaptation profiles enter the adaptation pipes till the mechanical stop. Now the wheelchair driver has to reach back with his arms to reach the levers for the locking brackets of the backrest. The wheelchair now needs to be tilted backwards and the locking brackets have to be opened by using the levers to allow the wheelchair backrest to lean against the **Stairmax**. Now the locking brackets have to be closed again so that they lock the wheelchair backrest. The tilting backwards has to be done by the use of manual force. Good arm functions are necessary to perform this action.



When attaching the wheelchair to the **Stairmax** the adaptation pipes have to run over the adaptation holder profiles. Now the wheelchair can be tilted backwards. When tilting backwards, the **Stairmax** is automatically attached to the wheelchair by locking of the adaptation hooks.

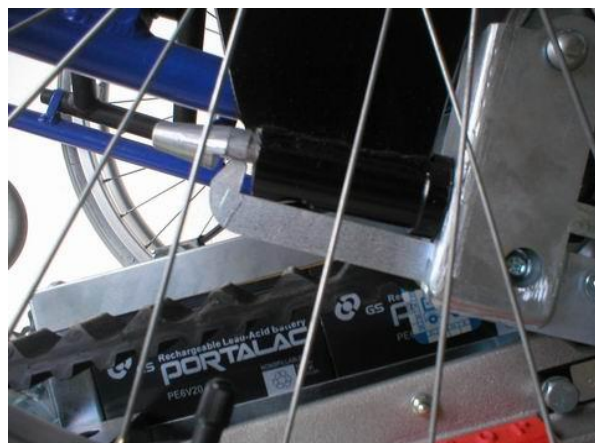
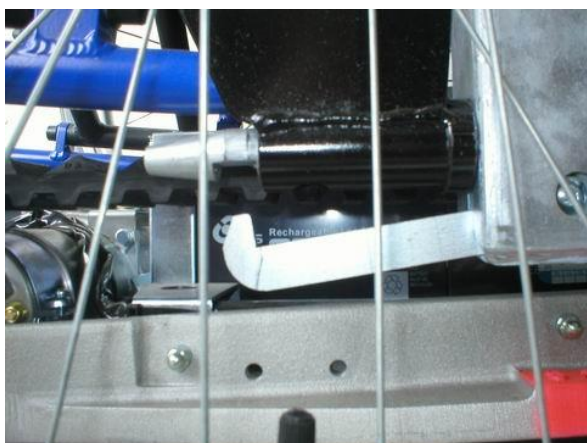



After tilting backwards and fixing of the wheelchair with the locking brackets the wheelchair driver always has to make sure that both sides of the wheelchair backrest are securely clutched by both locking brackets (on both sides).

In order to secure the locking brackets the red control lever, as shown in the section “Main control functions”, has to be brought into closed position. This locks the locking brackets and activates the drive switch.

Basically, after connecting the wheelchair to the **Stairmax** the vehicle is now ready to drive when the red control lever is in drive position (the locking brackets are locked). Nevertheless, it might be necessary to bring the **Stairmax** in the right drive position at the start of the stairs by using the horizontal drive position.

After careful adaptation of the wheelchair to the **Stairmax** and the examination of the stair gradient, the mobile stair lift can now be used. In general, after connecting the wheelchair to the **Stairmax** adapter the wheelchair driver has to understand 2 basic adapter positions to use the device safe and without problems.

- Position 1: The **Stairmax** is carried by the wheelchair, the adapter is lowered – this allows faster horizontal driving and turning on landings, using the manual force of the wheelchair driver. To get into position 1 the lifting switch has to be pushed to lift the **Stairmax** until it stops.
- Position 2: The wheelchair is carried by the **Stairmax**, the adapter is lifted – this allows the climbing and descending of stairs, as well as horizontal driving, using the **Stairmax** drive. To get into position 2 the lifting switch has to be pushed to lower the **Stairmax** until it stops.

Position 1: Horizontal driving

By pressing of the vertical lifting switch the **Stairmax** is lifted approximately 30 mm over the floor level. The **Stairmax** is carried by the wheelchair. In this position the **Stairmax** is attached to the wheelchair by the locking brackets and the adaptation hooks. Furthermore the switches for activating the drive are blocked so that only the wheelchair can move the **Stairmax**. Always make sure that the red control lever is in locked position so the locking brackets are secured.



The wheelchair driver can now move on horizontal areas, either for carrying the **Stairmax** from one location to another (e.g.: from the car to the stairs or from the stairs to a parking location) or to turn the **Stairmax** on landings between two stair flights.



Position 2: Driving on Stairs

After the **Stairmax** has been brought into the right position at the start of the steps it has now to be brought back into Position 2. Therefore the lifting switch has to be activated and pressed until the adapter is lifted to its upper position. This lifts the wheelchair over ground level, activates the drive switch and now allows to use the **Stairmax** drive.

Attention: Check locking brackets on both sides. Turn the red control lever till its mechanical stop. This blocks the locking brackets from being opened and unlocks the drive switches.

Driving upstairs

When approaching a stair it is essential that the **Stairmax** is positioned in line with the stair flight. The crawler type undercarriage of the **Stairmax** should be place min. 20 mm in front of the first step so as not to block the supporting roller when changing from position 1 (horizontal drive) to position 2 (driving on stairs). By activating the drive switch the wheelchair driver can now drive up the stairs.



When reaching the end of the stair, the **Stairmax** has to change back from being inclined in line with the stairs into a horizontal position. This requires to find the right moment of tilting the **Stairmax**. For each wheelchair driver this point is different, depending on the body weight of the driver and the construction type of the wheelchair used.

The wheelchair driver has to establish his individual tilting point by slowly approaching the first upper step. In general the tilting point is reached when the wheelchair axis passed the edge of the upper step. Here the **Stairmax** should be stopped and then it has to be tilted by holding on to the handrail and pushing the **Stairmax** back.

After the tilting backwards the **Stairmax** should be driven at least 200 mm backwards before it can be switched again to Position 1 (Horizontal drive or turning on landings).



After reaching the landing between two flights the **Stairmax** has to be changed from Position 2 to Position 1 to allow for horizontal driving. To facilitate the turning on landings between stair flights the **Stairmax** should drive upstairs on the inside of the stair as far as possible.

Driving downstairs

Similar to driving upstairs, when driving downstairs it is most important to find the right moment of tilting the whole **Stairmax** at the upper end of the stair.



The wheelchair driver has to establish his individual tilting point by slowly approaching the first upper step. In general the tilting point is reached when the wheelchair axis passed the edge of the first step. Here the **Stairmax** should be stopped and then it should be tilted by shortly holding on to the handrail and pushing the **Stairmax** forward.

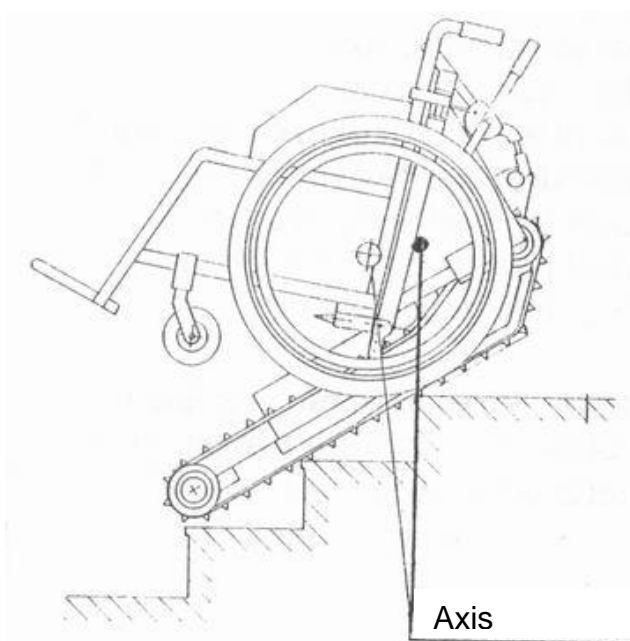

6. Width of landings

The landings between flights must be at least 110 cm wide. If the stair landing is less than 110 cm wide, a structural adjustment as shown on the sketch below makes the use of the **Stairmax** possible.

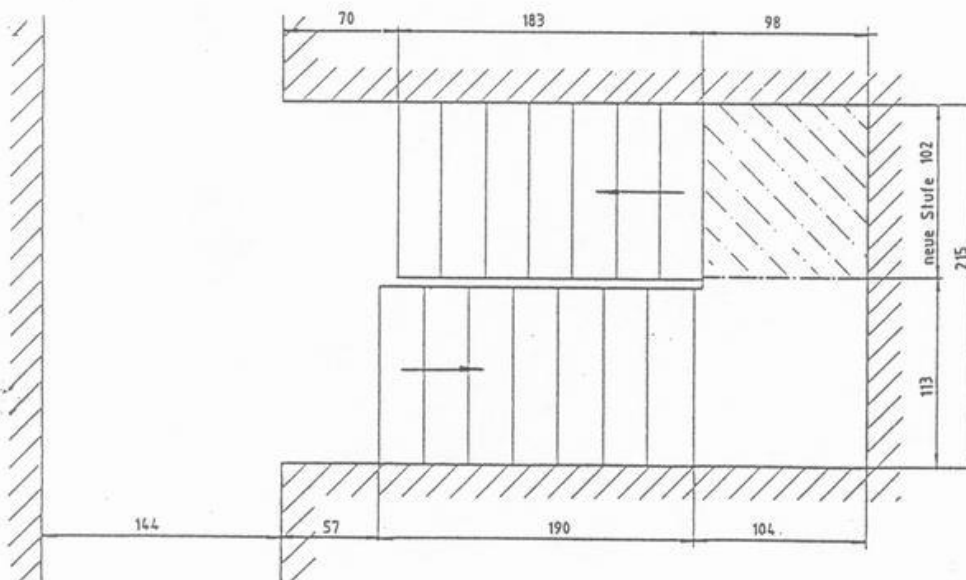
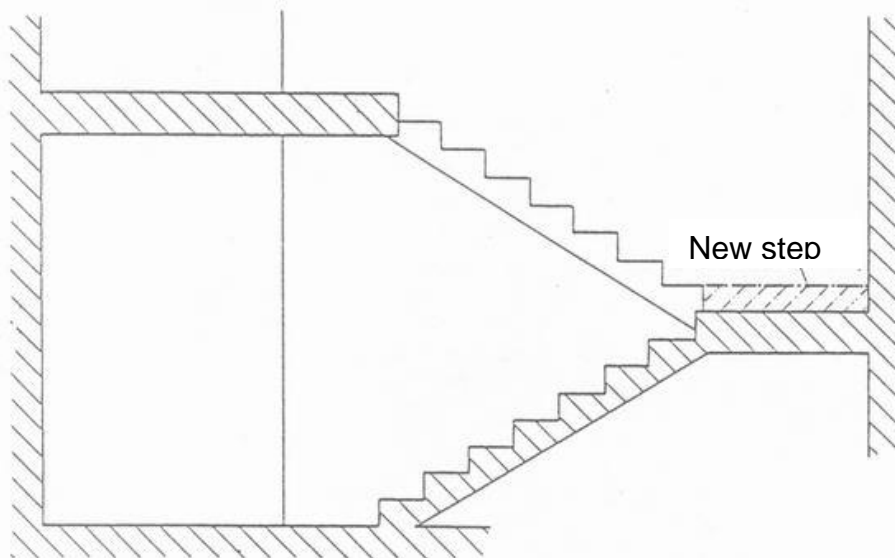

7. Maintenance

Batteries

The **Stairmax** is powered by two 6 Volt batteries which are maintenance-free and rechargeable. The batteries capacity allow to drive about 650 steps upstairs or for approximately 30 minutes when fully loaded. The charge state of the batteries is shown by indicator lamps located on the **Stairmax** drive which have to be checked before each operation. The recharge time varies according to the battery status but should not exceed the maximum of 8 hours.

The battery charger uses your AC power to reload the batteries. A 12 Volt charger is supplied with the batteries. An overloading of the batteries is not possible as the charger switches off when fully loaded. For more information please check the user manual of the charger.

Attention: The use of a non-adequate charger can damage the batteries. If an alternative charger is used please check if its compatible and don't use an acid battery charger.

Use of the charger

1. Disconnect the **Stairmax** cable from the battery box.
2. Connect the recharge cable with the battery box.
3. Connect the charger to a 220 V power socket.
4. The indicator lamps show that the batteries are loaded. When fully loaded the charger switches off.

Prolonging the battery life-time

The life-time of the battery can be prolonged by on-time recharging. If the battery is totally empty the recharge cycle can only be repeated approximately 180 times before the battery get unusable. But if the battery is reloaded when not totally empty the cycle can be repeated around 1200 times thus increasing the lifetime by the factor of 6.

If the battery is stored for a long time without being used it can be reactivated by using a stronger charger (shock-recharge) for a brief time and then using the normal charger to complete the recharge. In this case it is advisable to consult a expert company.

Please make sure that the emergency stop button is not switched because then there no power connection is given.

Storage of batteries

If not in use, batteries should be reloaded at least every 3 month. A very long storage time can cause that the batteries cannot be activated any more. This storage time varies according to previous operation, the loading state and the storage conditions.

For these reason only fully recharged batteries should be stored. Storage should occur distant to the charger and as cool and dry as possible.

Important: The electric discharge of the batteries increases significantly with higher temperatures. E.g. at 38° the batteries are empty after 5 month while at 10° only 8 % of the loading capacity would get lost. Batteries can be stored at temperatures down to -20°.

Rubber crawler

Parallelism

It is important that the lugs of the rubber crawlers are parallel to assure that they both touch the steps simultaneously.

Attention: If they are not parallel the **Stairmax** may not climb the stairs in a straight way and this can lead to a loss of balance. If the parallelism is not given please inform your **Stairmax** supplier for adjustment of the rubber crawlers.

Cleaning of the rubber crawlers

To achieve a maximum of friction between the rubber crawlers and the steps it is important that the rubbers crawlers (and the steps) are clean and free of oil or dirt. The rubber crawlers can be cleaned with wet towels or mild cleaning agents. It has to be assured that cleaning agents don't damage the rubber. We advise, independently of the steps, to clean the rubber crawlers at least 2 times a year. Please also thoroughly clean the stairs regularly.

Use of new rubber crawlers:

The rubber crawlers contain steel-wires that impede the overstretching of the rubber. These wires are covered by a thick rubber layer. The rubber crawlers are extremely durable but should be exchanged if they have cracks or cuts or other signals of damage. Exchange is also necessary if the rubber lugs are worn off and significantly smaller compared to their initial state.

Parking and transporting the *Stairmax*

The *Stairmax* can be brought into a space saving parking position by using a special parking ladder which can be supplied together with the *Stairmax*.

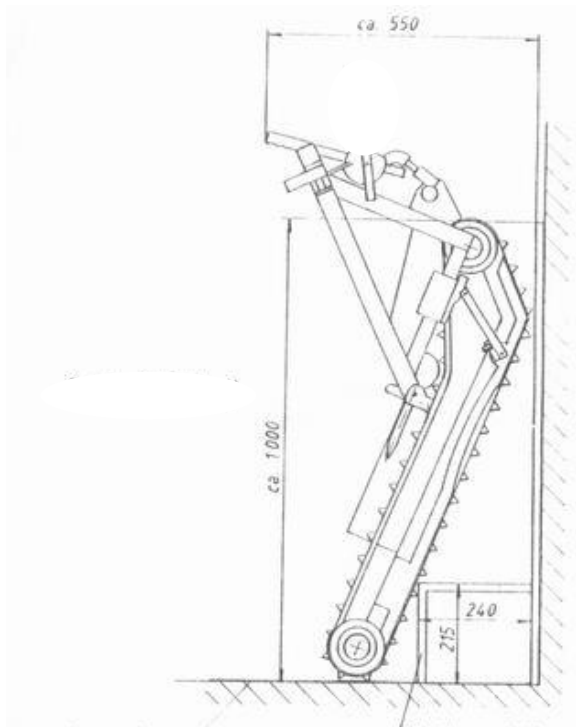

The same ladder can be used to move the *Stairmax* in and out of a car and enables for the easy transport from one location to another.

8. Technical details

Loading capacity	130	kg
Energy capacity (fully loaded)	650	steps
Dimensions:		
Length:	1473	mm
Width:	635	mm
Weight:		
Drive unit	31	kg
Adapter	25	kg
Battery	8	kg
Total	64	kg
Batteries	2 X 6	V/20AH
Charging voltage	4	Amp.
Motor	12	VDC
Speed		
upstairs	6.5	m/min
downstairs	7.7	m/min
Maximum stairs inclination	35	°

9. Error-check table

If the following error advises don't help to solve the problem please contact your supplier company.

<u>Error</u>	<u>Possible reasons</u>
Motor doesn't work	Key switch is off Battery is not connected Battery is empty Loose connection between battery and motor or the battery cells Emergency stop button is pressed
Charger doesn't load battery	Loose connection between charger and battery Charger damaged – please contact supplier company Battery defect – please contact supplier company
Stairmax drives skewed over stairs	Rubber crawlers are not parallel – please contact supplier company
Stairmax slips on stairs	Rubber crawlers are not parallel – please contact supplier company Rubber crawlers are dirty

10. Warranty

Warranty is 1 years from the date of delivery provided that a normal operation and care of the **Stairmax** is given.

Warranty is not valid in the case of improper use or damage on purpose, nor in the case of lost parts or damage through fire or water. Warranty is also not given in the case of damage due to improper revision of the handbook, through the use of unauthorized people or due to reparation through unauthorized people.

Warranty is limited to free of charge supply with repair parts, but does not account for transport costs.

The *Stairmax* has to be serviced once a year. Please contact your supplier company.